



Union Special
INDUSTRIAL SEWING EQUIPMENT

STYLES

**ADJUSTING INSTRUCTIONS AND
ILLUSTRATED PARTS LIST**

100P

100S

100LS

100TN

100NTN

**CLASS 100 STREAMLINE HIGH SPEED
SADDLE STITCH MACHINE**

**CATALOG
NO. 122L**

**SECOND
EDITION**

Catalog No. 122 L

LIST OF PARTS AND INSTRUCTIONS

FOR

OPERATING AND ADJUSTING

CLASS 100

STREAMLINED SADDLE STITCH
MACHINE

Styles	
100 P	100 LS
100 S	100 TN
100 NTN	

Second Edition

© 1962

By

Union Special Corporation
Rights Reserved in All Countries

UNION SPECIAL CORPORATION

INDUSTRIAL SEWING MACHINES

CHICAGO

Printed in U.S.A

April, 1981

FOREWARD

The dominating idea back of Union Special is to build the best industrial sewing machines in the world. The high speed streamlined saddle stitch machines are a pronounced achievement along these lines. All parts are made to precision gauges insuring complete interchangeability. A few of the outstanding features are:

1. Streamlined design. Pleasing in appearance, this natural functional design provides greater stability and ruggedness, free from difficult-to-clean recesses.
2. Simplified oiling. Automatically supplies oil to lower main shaft bearings, feed rocker and feed lift bearings.
3. Acceleration. The machine is brought to top speed in an instant - for higher productive rates and lower costs.
4. Push button control, for quick, easy adjustment of stitch length, with a stitch length indicator of the comparison type, using letters as a means of reference, to predetermine stitch lengths.

It is our constant aim to furnish carefully prepared information that will enable the customer to secure all possible economies and advantages from the use of UNION SPECIAL machines. The following pages contain valuable operating and adjusting data and illustrate and describe the parts for Styles in Class 100 streamlined saddle stitch machines.

Union Special representatives will be found in all manufacturing centers, ready to cooperate with you to plan and estimate requirements.

UNION SPECIAL CORPORATION

Engineering Department

APPLICATION OF CATALOG

This catalog applies only to the standard styles of machines as listed herein. All references to directions, such as right and left, front and back, etc., are taken from the operator's position while seated at the machine. The direction of rotation of the handwheel is toward the operator.

IDENTIFICATION OF MACHINE

Each UNION SPECIAL machine carries a style number which is stamped in the name plate on the machine. Style numbers are classified as standard and special. Those which are standard have one or more letters suffixed, but never contain the letter "Z". Example: "100 LS". Style numbers containing the letter "Z" are special.

Styles of machines similar in construction are grouped under a class number which differs from the style number in that it contains no letters. Example: "100".

The serial number of the machine is stamped on the back of the column at cloth plate level.

STYLES OF MACHINES IN CLASS 100

With the exception of Styles 100 TN and 100 NTN, all the machines in Class 100 are used for producing a decorative saddle stitch. Recommended speed is 2000 R. P. M.

100 P For pick or pin point saddle stitch edging on collars and pockets of sport shirts; also for side seams of trousers and slacks. Needle travel 15/16 inch. Stitch range is 3 to 5 stitches per inch.

100 S Similar to Style 100 P, except regular saddle stitch length for edging on collars and pockets of sport shirts, side seams of trousers and slacks, and on infants' knitted wear. Needle travel 15/16 inch. Stitch range is 3 to 5 stitches per inch.

100 LS For long or giant saddle stitch edging on ladies' wear, such as dresses, fall coats, skirts, etc. Needle travel 15/16 inch. Stitch range is 2 1/3 to 3 1/2 stitches per inch.

*100 TN For necktie closing, joining tie, lining strip and band. Needle travel 1 1/32 inch. Equipped with attachment for centering lining and tape. Machine may be used with or without tape. Stitch range is 2 1/4 to 3 stitches per inch.

* NOTE: Style 100 TN was formerly known as Style 100 NTN, so any reference to Style 100 NTN would apply to Style 100 TN.

INSTALLING

Each machine, as it leaves the factory, is sewed off, inspected and carefully packed. When the machine reaches the customer, it is ready for service. Because of all the precautions taken by those who handle the machine, the customer needs only to place it in its proper position in the table and make only the ordinary settings to adapt the machine to the material he wishes to sew.

STANDARD ACCESSORIES

Included with each machine is a box of standard accessories containing one drip pan, oil drain jar and clamp spring, one knee lifter assembly and rubber pad, one spool pin, two hinge studs, one machine rest pin, two hinge plates and screws, four felt pads and necessary nails. These parts are indispensable when setting up the machine.

INSTALLING (Continued)

TABLE TOPS

Machine Styles 100 P, 100 S, 100 LS may be installed in table top No. 21371 NB-48 prepared with cut-out so that the bed plate is flush with the top of the table. Isolated mounting parts are included with the table top. For table tops not prepared for isolated mounting, use the felt pads and nails furnished with the accessories.

When assembling the hinge plates to the table tops, be sure to locate them as accurately as possible, so that the hinge studs, attached to the machine, can swing properly in the plate.

Special care should be taken that machine does not contact the sides of the cut-out at any point.

Style 100 TN is mounted on a machine base which, in turn, is screwed directly to the table top. This machine may be installed on table top No. 21371 VG-48.

KNEE PRESS

The knee press is attached to Union Special table tops at the location designated by punch marks on the underside. For other boards, locate the knee press so that the center of the shaft is 8 1/4 inches from the right side of the cut-off. The knee press assembly should appear as in (Fig. 1).

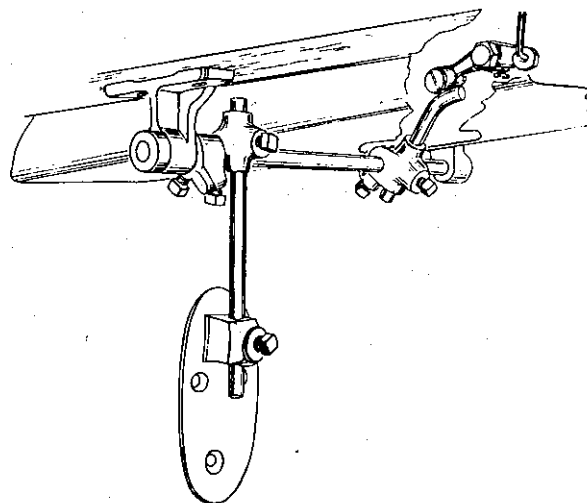

Fig. 1

DRIP PAN

The drip pan is attached to Union Special table tops at the indentation marks on the inside of the cut-out, using the nails furnished with the accessories. For other table tops, the drip pan should be set high enough to clear the knee press and low enough to clear the bottom of the machine. It should be laterally located so that it is directly under the base of the machine.

BELTS

These machines are equipped to use either No. 1 "V" or round belt.

LUBRICATION

CAUTION!!

The oil has been drained from the main reservoir and the hook shaft gear case before shipment, and these reservoirs must be filled before starting to operate. Lubricate machine thoroughly in accordance with instructions and run slowly for several minutes to distribute the oil to the various parts. Full speed operation can then be expected without damage.

RECOMMENDED OILS

Use a straight mineral oil of a Saybolt viscosity of 90 to 125 seconds at 100° Fahrenheit in main reservoir and hook shaft gear case. This is equivalent to Union Special oil specification No. 175.

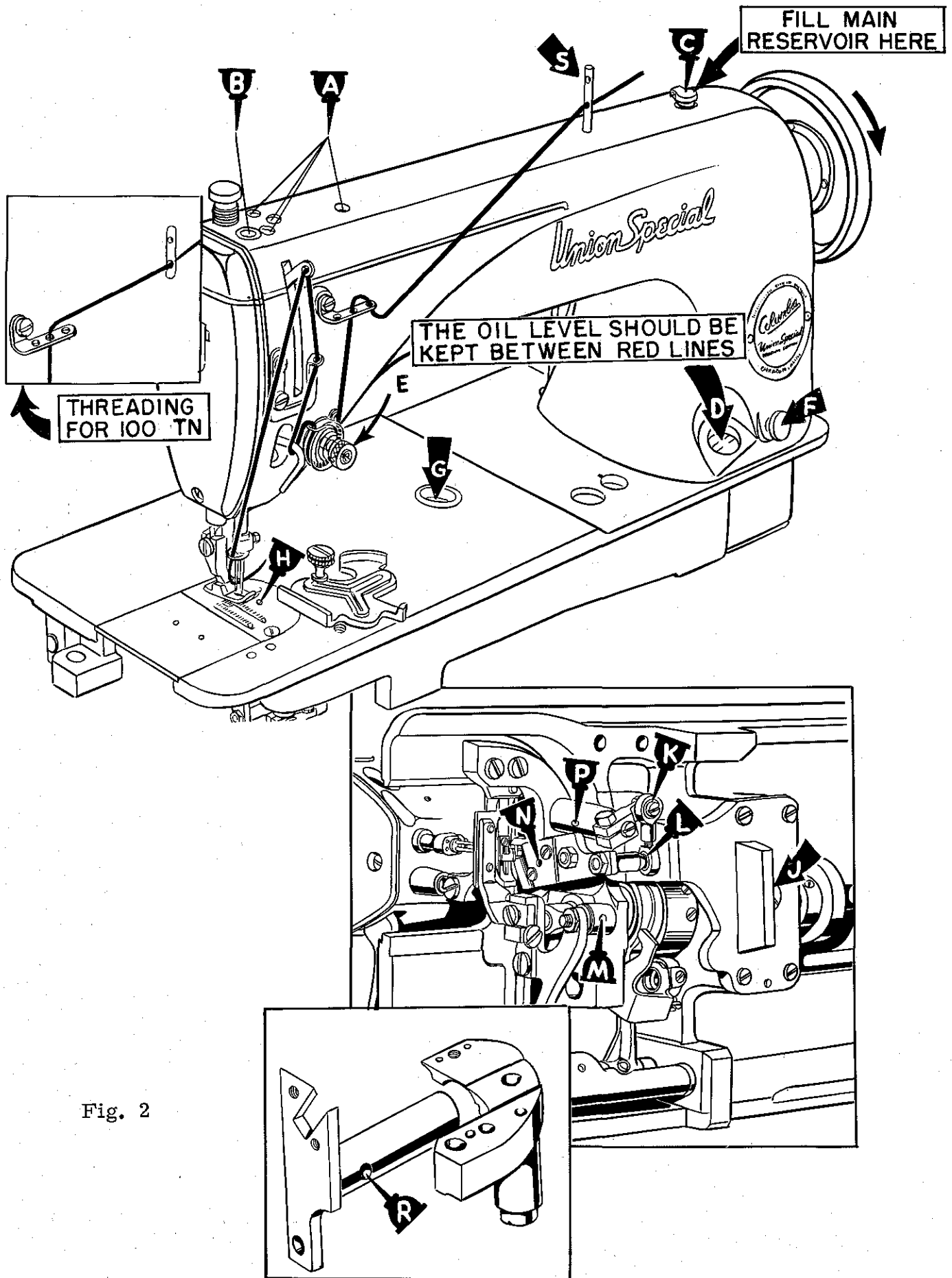

Fig. 2

LUBRICATION (Continued)

RECOMMENDED OILS (Continued)

Oils conforming to specification No. 175 may also be used in the manually oiled places.

For trouble free operation, oil the machine as indicated in the diagram (Fig. 2).

With needle bar at the top of its stroke, oil the holes (A) twice daily. In oiling hole (B), very little oil should be used and only around the outer edges of the needle bar. Do not put oil into the hole in the needle bar, as it will flow out when machine is operated at high speed. A can of oil, No. 28604 R, is included with the accessories packed with the machine. It contains a sufficient quantity to fill both reservoirs. The main reservoir is filled through oil cup (C) and the supply is usually replenished about twice a month. However, the oil level should be checked from time to time and kept between the lines on the gauge (D).

The hook shaft gear case is filled at the plug screw hole (J). A quantity of oil sufficient to bring the level up to the plug screw hole, when the machine is tilted back against the rest pin, should be used. Remove plug screw and check the level of oil about every six months.

CAUTION!!

Do not use a compounded oil in the feeding drive shaft gear case or hook shaft gear case, as these oils separate and froth.

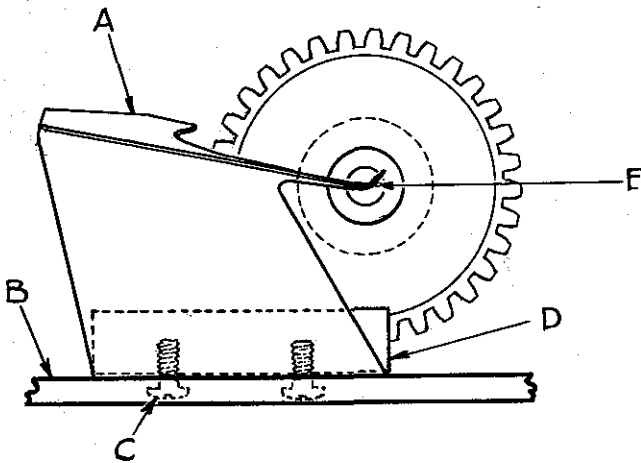

Fig. 3

Lubrication of most of the mechanism below the bed plate is automatically accomplished through the feed driving shaft which is tubular. Oil is introduced into the shaft at the gear end by means of an oil distributing plate (A, Fig. 3) which is secured to the large gear case cover (B) by means of two screws (C) and retaining block (D).

Should it ever become necessary to remove any of the parts from the gear case, it is imperative that the adjustment of the oil distributing plate be checked very carefully. This can be done by removing the large plug screw at the right end of the gear housing and looking through the hole. The low point of the oil distributing plate must be even with or slightly below the center of shaft (E) and just touching it. This is a very important adjustment as the functioning of the automatic lubrication of the lower part of the machine depends upon it.

The hook driving mechanism, below the bed plate, is manually lubricated, and the oiling places are indicated at (H, K, L, M, N, P, and R, Fig. 2). A few drops daily at these points will be sufficient.

NEEDLES

Use only genuine UNION SPECIAL needles.

The recommended needles for these machines are Type 29-C150 or 29 DEA, eye needle, (formerly System 150) and Type 29-C151, hook needle, (formerly System 151 SU). The minor number following the Type Symbol indicates the size.

NEEDLES (Continued)

These needles are available in the following sizes:

NEW TYPE NO.	OLD SYSTEM NO.	DESCRIPTION	SIZE
29 DEA-090/036	4/150	Eye Needle	.038
29-C150-5	5/150	Eye Needle	.042
29 DEA-110/044	6/150	Eye Needle	.044
29 DEA-140/054	8/150	Eye Needle	.054
29-C151-4	4/151	Hook Needle	.038
29-C151-5	5/151 SU	Hook Needle	.042
29-C151-6	6/151 SU	Hook Needle	.046
29-C151-7	7/151 SU	Hook Needle	.050
29-C151-8	8/151 SU	Hook Needle	.054
29-C151-10	10/151 SU	Hook Needle	.062

Style 100 P is set with 29-C150-5 or 5/150 eye needle and 29-C151-5 or 5/151 SU hook needle and No. 60 cotton thread. Finer needles and cotton may be used on this machine. To use heavier threads such as 40-30 cotton or 2/3 rayon twist, it is necessary to change the needle spacer to C1021 P-073 and to use 29 DEA-110/044 or 6/150 eye needle and 29-C151-6 or 6/151 SU hook needle.

Style 100 S for sportswear is set with 29 DEA-110/044 or 6/150 eye needle and 29-C151-7 or 7/151 SU hook needles and C3 saddle stitch rayontwist. For trousers, use 29 DEA-110/044 or 6/150 eye needle and 29-C151-6 or 6/151 SU hook needle with No. 50 or size A cotton. Finer needles and thread may also be used.

Style 100 LS is set with 29 DEA-140/054 or 8/150 eye needle and 29-C151-10 or 10/151 SU hook needle with size E cotton thread. Finer needles and thread may be used.

Style 100 NTN is set with 29-C150-5 or 5/150 eye needle and 29-C151-5 or 5/151 SU hook needle with size 00 mercerized.

To have orders promptly and accurately filled, an empty container, a sample needle, or the type number should be forwarded.

OPERATOR'S INSTRUCTIONS

INSERTING THE NEEDLES

Insert the needles in the needle bar as far as they will go, with the spots or scarfs to the right, and with the eye needle in the rear hole and the hook needle in the front.

THREADING

Thread machine in accordance with threading diagram (Fig. 2).

The main diagram illustrates the threading for Styles 100 P, 100 S and 100 LS. The insert illustrates the difference between the threading of Style 100 NTN and the other styles.

Please note that on Style 100 NTN, when fine nylon (Z15 size) or fine cotton (2/0 size) threads are used, the threading of the check spring and take-up lever is omitted.

OPERATOR'S INSTRUCTIONS (Continued)

NEEDLE THREAD TENSION

The needle thread tension is varied by turning the tension regulating nut (E, Fig. 2). Turning the nut in a clockwise direction increases the tension and counterclockwise decreases the tension. This should not be done when the presser foot is in its raised position, and is generally done while the machine is sewing on a piece of scrap material.

LENGTH OF STITCH

The showing stitch remains the same, but the space between the stitches changes when setting for a longer or shorter stitch. The total length of stitch can be set from approximately 3 to 10 stitches per inch on Styles 100 P, 100 S, 100 LS, and from approximately 2 1/3 to 10 stitches per inch on Style 100 NTN. Most tie manufacturers, however, prefer the maximum stitch length.

TO CHANGE THE STITCH LENGTH

Press plunger (F, Fig. 2) in firmly. While holding plunger in, turn handwheel in operating direction until stitch regulating finger is felt to drop into the slot of feed eccentric. Continuing to hold the plunger in, turn handwheel in operating direction to increase the stitch length and in opposite direction to decrease the stitch length.

Comparative stitch lengths are indicated by the graduations on the dial (G) in bed plate, ranging from S (short) to L (long). Release the plunger.

The stitch regulating plunger may be locked at any setting by means of the locking screw located on the underside of the bed plate lip directly below the plunger.

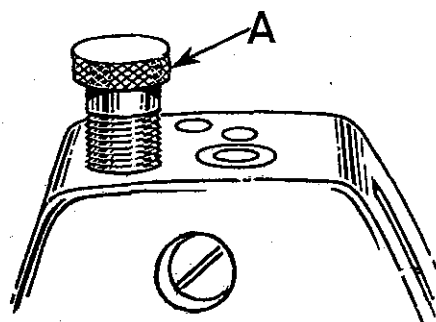

Fig. 4

PRESSURE ON MATERIAL

The presser spring should exert only enough pressure to make the work feed uniformly. To increase the pressure on the presser foot, turn the presser spring regulator (A, Fig. 4) in clockwise direction. Turning the regulator counterclockwise decreases the pressure.

OPERATING STYLE 100 NTN

Raise the presser foot on the machine with the knee lifter. Then, draw the tie lining into the stretching device (A, Fig. 5) through the lining guide (B) and under the presser foot, placing the edge of the lining against the ruler edge guide (C) with the end of the lining located at whichever number you choose to use as a starting point.

A tape slot (D) is provided in the plate, for the tape which is drawn in simultaneously with the tie lining. Its use is optional. Many operators work with the tie linings draped across their right knee. If this method is used, the lining should be inserted under the angular guide (F). If the operator prefers to let the tie linings hang straight down, the angular guide (F) should be removed.

The tie is now placed under the presser foot and against the adjustable tie gauge (E). Tie and lining are now sewn together the entire length.

OPERATOR'S INSTRUCTIONS (Continued)

OPERATING STYLE 100 NTN (Continued)

To remove the tie, be sure the needles are up and have just started their downward travel. Then, raise the presser foot with the knee lifter. With the left hand, draw the tie at least 1 inch to the rear to pull off thread. Then, break the thread by snapping the tie to the rear left.

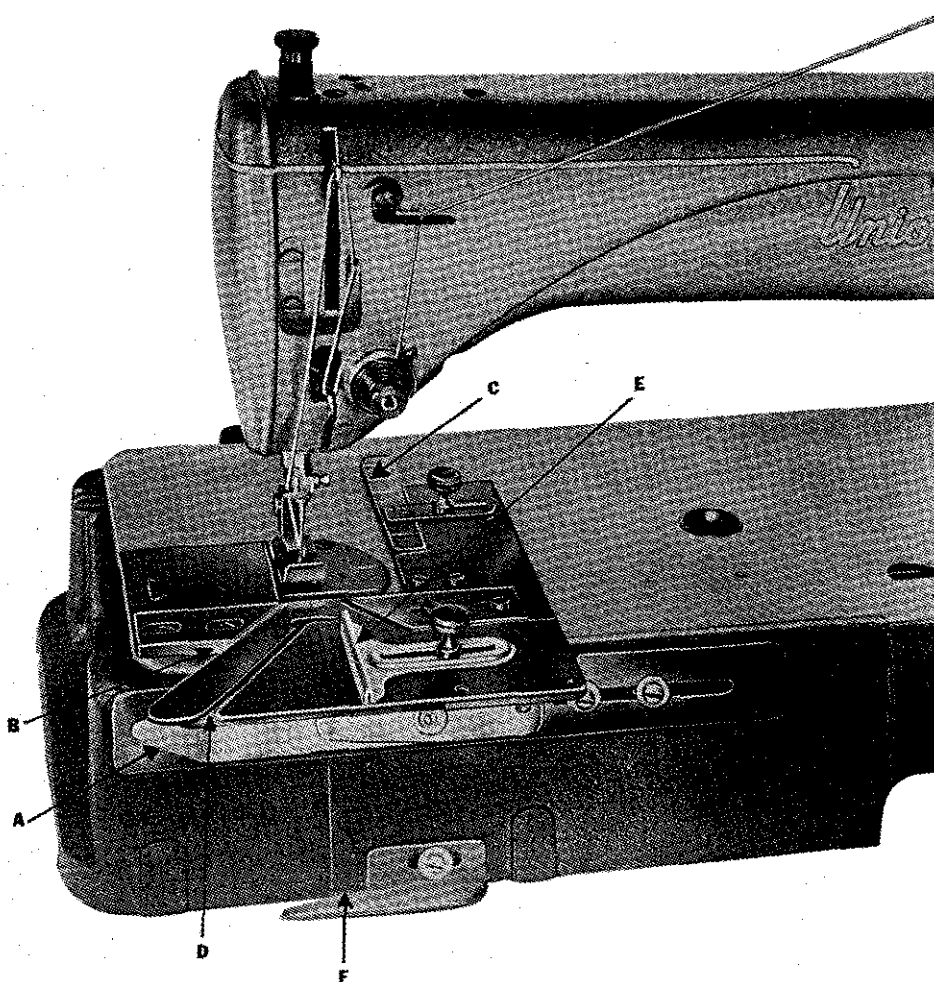

Fig. 5

The forward portion of the slot in the presser foot has a knife edge so that threads which will not break by the above method may be readily cut. When using nylon or heavier threads, proceed as outlined above, then, draw tie to the left, lowering the presser foot at the same time to sever threads.

The ruler edge guide (C) can be moved to the left or right to center the lining so that the stitching will be in the center of the lining. The marks on ruler edge guide (C) are used for locating the starting position on lining and tie.

The lining stretching device (A) has an adjustable tension. If the lining is puckering, more tension is required on the stretching device (A). Light weight linings require less tension than heavy weight linings. Linings must be cut on the bias. When the stitching is not centered on the tie lining, it may be necessary to move the lining stretching device (A) to the left or right of center line.

MECHANIC'S INSTRUCTIONS

SETTING THE NEEDLE BAR TO HEIGHT

The lower needle bar bushing, the one to which the needle bar is timed, is set at the factory. The distance from the bottom of the bushing to the throat plate seat is 2.298 (2 19/64) inches (Fig. 6).

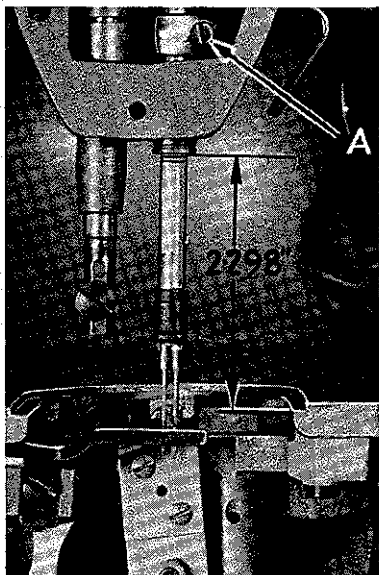

Fig. 6

When the needle bar is in its lowest position, the upper timing line on the needle bar should be even with the lower edge of the needle bar bushing. To change the position of the needle bar, turn the handwheel in operating direction until the needle bar is in its lowest position, then, loosen the clamp screw (A) and move the bar to the proper timing line. Insert a pin in the 3/64 inch hole between the timing lines and turn the needle bar 3 to 5 degrees to left of the line of feed on 100 P and 100 NTN machines, 2 to 3 degrees on 100 S machine, and 1 degree on 100 LS machine.

FEED DOG HEIGHT

In regulating the height of the feed dog, it should be at its highest position and the presser foot resting directly against it. Feed dog should show the depth of a full tooth above the throat plate.

The feed dog holder attaching screw (A, Fig. 7) should be loosened slightly, and regulating screw (B) should be turned either clockwise to raise the feed dog, or counterclockwise to lower it. Make sure that the bottom of the shank of the feed dog holder rests against the head of the regulating screw.

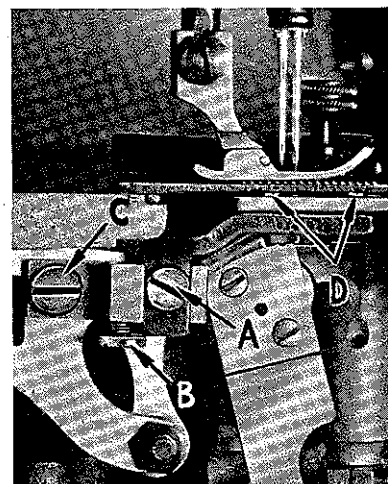

Fig. 7

The feed dog can be tilted up or down as required by loosening screws (A and C).

Loosen feed dog holding screws (D) to space the feed dog, front to back or sideways in throat plate.

PRESSER FOOT HEIGHT

With the feed dog at the bottom of its stroke, set the presser foot height so that there is 1/4 inch space between the bottom of the presser foot and the top of the throat plate when the presser foot lifter lever is at its highest position.

To make this adjustment, loosen screw (D, Fig. 8), and with the hand lifter (B) in its up position, move the presser bar to secure the desired height of foot and re-tighten screw (D). When the above adjustment is made, care must be taken that the needles are centered in the presser foot needle slot.

PRESSER BAR CONNECTION

The presser bar connection (A, Fig. 8) should be set so that it is 1/16 inch from the hand lifter (B) at all times.

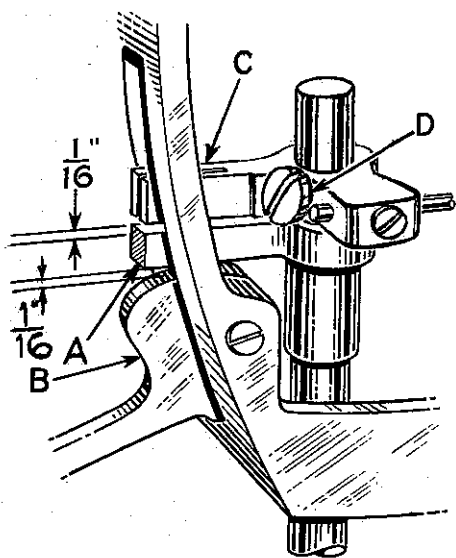

Fig. 8

MECHANIC'S INSTRUCTIONS (Continued)

PRESSER BAR CONNECTION (Continued)

This is accomplished by turning the machine over on its side, loosening lock nut (G, Fig. 9) and relocating the stop screw (E) on the lifter lever bell crank (F). By turning the stop screw counterclockwise, the presser bar connection is brought closer to the hand lifter. Turn the stop screw to secure desired 1/16 inch space. Tighten lock nut (G) to lock screw in position.

PRESSER BAR GUIDE

When locating the presser bar guide (C, Fig. 8), the presser foot must rest directly against the throat plate with the feed dog in its lowest position.

The guide is properly set when there is a 1/16 inch space between presser bar guide and the connection.

To obtain this setting, loosen set screw (D) in the guide and insert screw driver between the connection and the guide. Tap on presser foot to insure its being down on the throat plate, center the foot by turning it so that needle enters the middle of its slot and re-tighten screw (D) in guide.

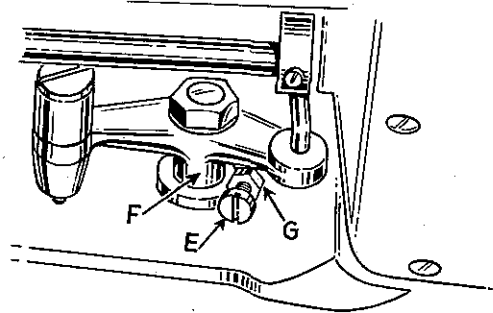

Fig. 9

THREAD CONTROL

Test check spring tension (A, Fig. 10). There should be enough tension to insure a good returning snap when spring is depressed and released. Should it require adjusting, loosen set screw in the head on right side of tension post (G, Fig. 12) and remove tension post assembly. Partially loosen tension post set screw (B, Fig. 10) in tension post socket (C). Holding the socket in the left hand, turn the tension post (D) counterclockwise with the right hand until

the check spring moves away from the upper stop (E) and has no tension on it. Turn the tension post (D) in a clockwise direction until the spring again touches the upper stop (E). Then, proceed further in the same direction until the desired tension is obtained. When correctly set, the tension post set screw (B) should be drawn up snugly, but not forcefully. Further adjustment of the check spring tension can be made by inserting a screw driver into the slotted end of the tension post (D) and turning in the required direction.

Replace tension assembly with the check spring about 3/8 inch above the thread take-up wire. While the tension post assembly is being replaced, the presser foot should be resting on the throat plate.

The frame take-up eyelet (A, Fig. 11) should be set at its highest position.

For the final setting of check spring, sew slowly on a piece of material and observe the action of the check spring. The spring should have completed its travel and rest against its stop as the needle bar reaches the bottom of its stroke.

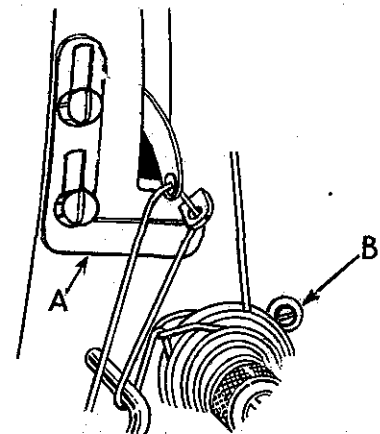

Fig. 11

LOCATING TENSION RELEASE MECHANISM

The tension assembly should be located in bed from front to back, so that when the presser foot is raised to its highest position, the tension discs (F, Fig. 12) are opened just enough to allow the thread to pass through the discs freely.

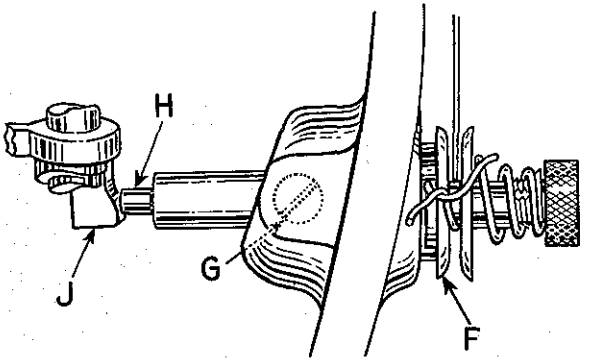

Fig. 12

To position the tension assembly, see that set screw in bed (G, Fig. 12) is loose and tension assembly adjusting screw (B, Fig. 11) is screwed down to the bed.

Lift the presser foot hand lifter to its highest position. With the left hand, grasp the thread and pull it through the tensions, with the right hand, push tension post deeper into the machine until release pin (H, Fig. 12) pressing against the presser bar connection (J) has opened the tension discs just enough to allow the thread to pull through freely.

Re-tighten set screw (G), turn tension assembly adjusting screw (B, Fig. 11) counterclockwise until it contacts the flange of the tension post socket.

SETTING THE HOOK ON THE CARRIER

Set the hook high on the carrier and tilt backwards as far as it will go. Use screws (A, Fig. 13) to make this adjustment. Care must be taken that the hook point does not contact the bottom of the plunger after making this adjustment.

TIMING THE HOOK

Turn handwheel in operating direction until the needle bar has started to rise from its lowest position and the timing line (A, Fig. 14) at bottom of 3/64 inch hole is even with the bottom of the lower needle bar bushing. At this time, the point of the sewing hook (B) should be even with the centerline of the eye needle on the 100 P and 100 NTN machines, centered between the eye needle and the hook needle on the 100 S machine and 1/16 inch past the eye needle in its direction of travel on the 100 LS machine. The above adjustment may be made by loosening the three screws (E, Fig. 16) in the hook driving barrel and rotating the barrel until the above condition is satisfied.

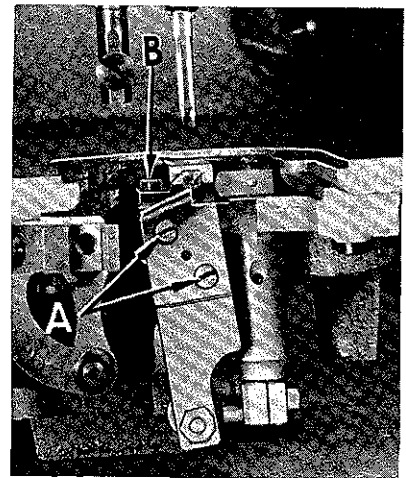

Fig. 13

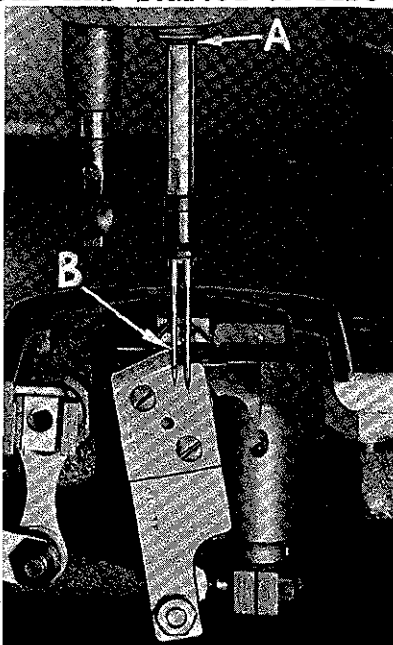

Fig. 14

Set the hook point as close as possible to the eye needle without contacting it on the 100 P, 100 S, 100 NTN machines. - The 100 LS machine will require a .003 to .005 inch space between the sewing hook point and the scarf of the eye needle.

MECHANIC'S INSTRUCTIONS (Continued)

TIMING THE HOOK (Continued)

This is done by loosening the Allen screw located in the lower bracket. Move the sewing hook shaft bushing (D, Fig. 16) either to the left or right to locate the sewing hook properly. Re-tighten the Allen screw.

TIMING THE PLUNGER

The plunger should pass midway between both needles on Styles 100 P and 100 NTN. On Style 100 S, the plunger should be .010 inch from the hook needle. On Style 100 LS, the plunger should be .005 inch from the hook needle. Loosen the plunger block holder screw (B, Fig. 13) and move the block in the required direction to make this adjustment.

Set the plunger so that the vertical portion (A, Fig. 15) extends $\frac{3}{64}$ inch beyond the left side of needles at its farthest point of travel to the left.

This adjustment is made by loosening clamp screw (B) and turning slotted shaft (C) in the required direction.

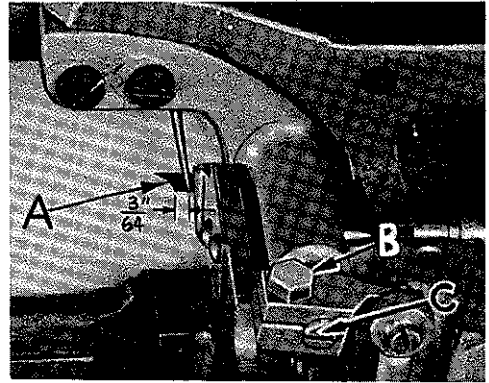

Fig. 15

STITCH FORMATION

Place cloth under foot and thread machine. Lay machine on its side and turn handwheel in operating direction and observe how the thread is carried between the needles into the hook needle by the plunger. As the thread is released by the sewing hook and plunger, it is drawn up by the take-up, and the feed motion completes the stitch. Any burr or sharp groove on the plunger or sewing hook must be removed. To turn cloth at desired corner or point, lower hook needle until the point is $\frac{1}{16}$ inch above cloth. Raise presser foot and make turn.

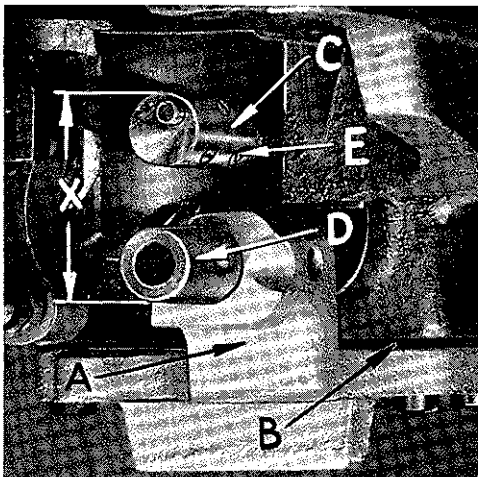

Fig. 16

On Styles 100 P, 100 S, and 100 NTN, at least one shim gasket must be used, and on Style 100 LS, at least one gasket on each side of the spacing plate must be used to prevent oil leakage.

Refer to parts list in back of book for shim gasket part numbers and thicknesses.

HOOK CARRIER BRACKET

Should it become necessary to replace either the hook carrier bracket (A, Fig. 16) or the shim gasket (B) for it, it is extremely important that the proper distance between the hook barrel (C) and hook carrier bushing (D) be maintained. Use a micrometer to check this dimension as shown at "X" in Fig. 16. On Styles 100 P, 100 S, and 100 NTN, this dimension is 1.375 inch plus .005 inch and on Style 100 LS, it is 1.400 inch plus .005 inch.

In order to achieve this adjustment, it will be necessary to select shim gaskets of the proper thickness to use between the hook carrier bracket (A) and the bed casting.

FEED TIMING

This timing is the relationship which exists between the feed dog and the needle bar motions.

Set the stitch regulator for the longest stitch. Set the feed dog to show the depth of a full tooth above the throat plate. Turn handwheel in operating direction until the bottom of the descending needle eye is even with the top surface of the throat plate. When the needle bar is in this position, the top of the feed dog teeth should be even with the top surface of the throat plate. A simple method of advancing or retarding the feed timing is provided in the head of the machine. Loosen the two screws holding the counterweight to the segment plate (A, Fig. 17) and the two screws (B) holding the counterweight to the main shaft. Hold the handwheel and turn the counterweight in a clockwise direction to retard the feed, and in a counterclockwise direction to advance the feed. Be sure to re-tighten all four screws securely, making certain that the counterweight does not slip. Any time the feed timing is changed, it is necessary to retime the hook.

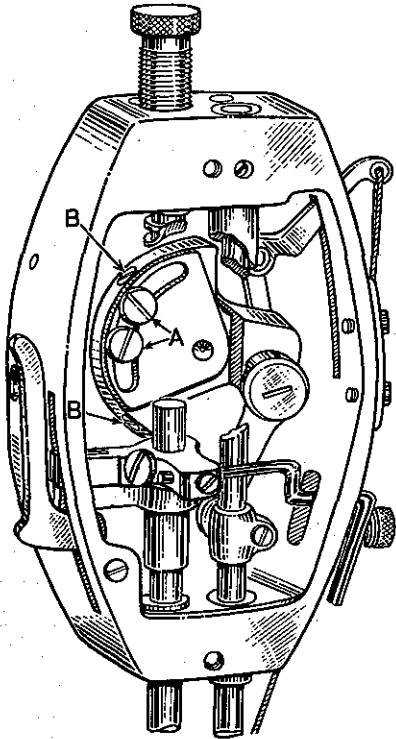

Fig. 17

MACHINE TIMING

If at any time the machine is disassembled, the machine will have to be retimed as follows:

1. Lay machine on its side on the bench.
2. Remove the large gear housing cover. Note: Caution should be observed that machine is tilted far enough back so oil will not leak out. Also, be careful in removing the housing cover that the gasket is not mutilated.
3. Loosen screws (B, Fig. 18) and slide gear (A) to the extreme right so it is out of mesh with the idler gear (D).
4. Looking through the stitch length indicator window on the top of the bed plate, rotate the lower main

shaft (C) in the operating direction until the timing mark "T" appears between the pointers of the indicator window. Then, rotate upper main shaft in the operating direction until the needle bar reaches its highest position and descends 1/64 inch on Styles 100 P, 100 S, and 100 NTN and 1/16 inch on Style 100 LS. Carefully turn gear (A) without disturbing the lower main shaft setting until the set screw lies directly above the flat in the lower main shaft. The gears should then be engaged as closely as possible in this position. While holding the gear and thrust collar (E) tightly between thumb and forefinger, tighten set screw against flat in shaft securely, then, tighten the second set screw and check to see that there is no play in the shaft, and that the machine revolves freely.

5. Clean, dry and re-seal gasket and housing cover using gasket cement.
6. Replace housing cover. Check position of oil distributing plate as previously described under "Lubrication".
7. Re-set hook.

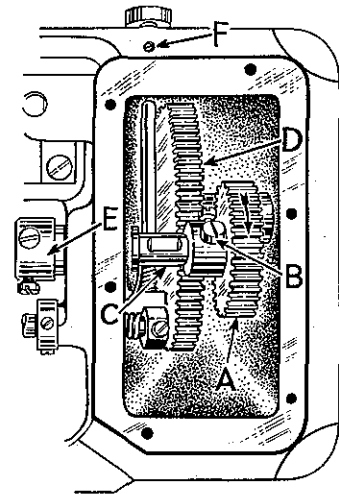

Fig. 18

USEFUL SUGGESTIONS

If the machine fails to work satisfactorily, though apparently in good repair, it is possible that some minor trouble exists. For this reason, delay may be avoided by acting on the following:

1. See that the needles are set properly; that they are the recommended needles; that they are straight and free from nicks and rough places; that they are inserted in the needle bar as far up as they will go; and that there is clearance all around needles as they enter the throat plate.
2. See that the machine is threaded correctly and the needle thread is delivered to the machine properly.
3. See that the proper tension is applied to the thread.
4. See that the presser foot is set so that the needle does not strike it.
5. See that the feed dog is not striking the hook or throat plate.
6. Take off throat plate and remove accumulated lint from feed dog slots and hook.
7. See that there are no nicks or cuts in the wall of the throat plate needle hole. String out this hole with fine emery cord or cloth.
8. See that the take-up spring acts freely, is not grooved or nicked. Remove any gummy oil and dirt around tension discs.
9. See that the point of the hook is not blunted, broken or nicked.
10. See that the hook is timed correctly.
11. See that the feed is timed correctly.
12. See that the plunger is set correctly.
13. See that all screws are tight.

ORDERING REPAIR PARTS

ILLUSTRATIONS

This catalog has been so arranged as to simplify the ordering of repair parts. Exploded views of the various sections of the mechanism are shown so that the parts may be seen in their actual position in the machine. On the page opposite the illustration will be found the listing of the parts with their part numbers, descriptions and the number of pieces required in the particular view being shown.

The numbers in the first column are reference numbers only and indicate the position of the part in the illustration. The reference number should never be used in ordering parts. Always use the part number shown in the second column.

Those component parts of sub-assemblies which can be furnished for repairs are indicated by the fact that their descriptions are indented under the descriptions of the main sub-assembly. Example:

45	61149	Stitch Length Indicator -----	1
46	95	Set Screw-----	1
47	96	Time Spot Screw - - - - -	1

In those cases where the parts for the various styles in Class 100 are not the same, the difference will be shown in the illustrations and descriptions. When a part is used in all machines covered by this catalog, no machine style will be mentioned.

At the back of the book will be found a numerical index of all the parts shown in this book, which will facilitate locating the illustration when only the part number is known.

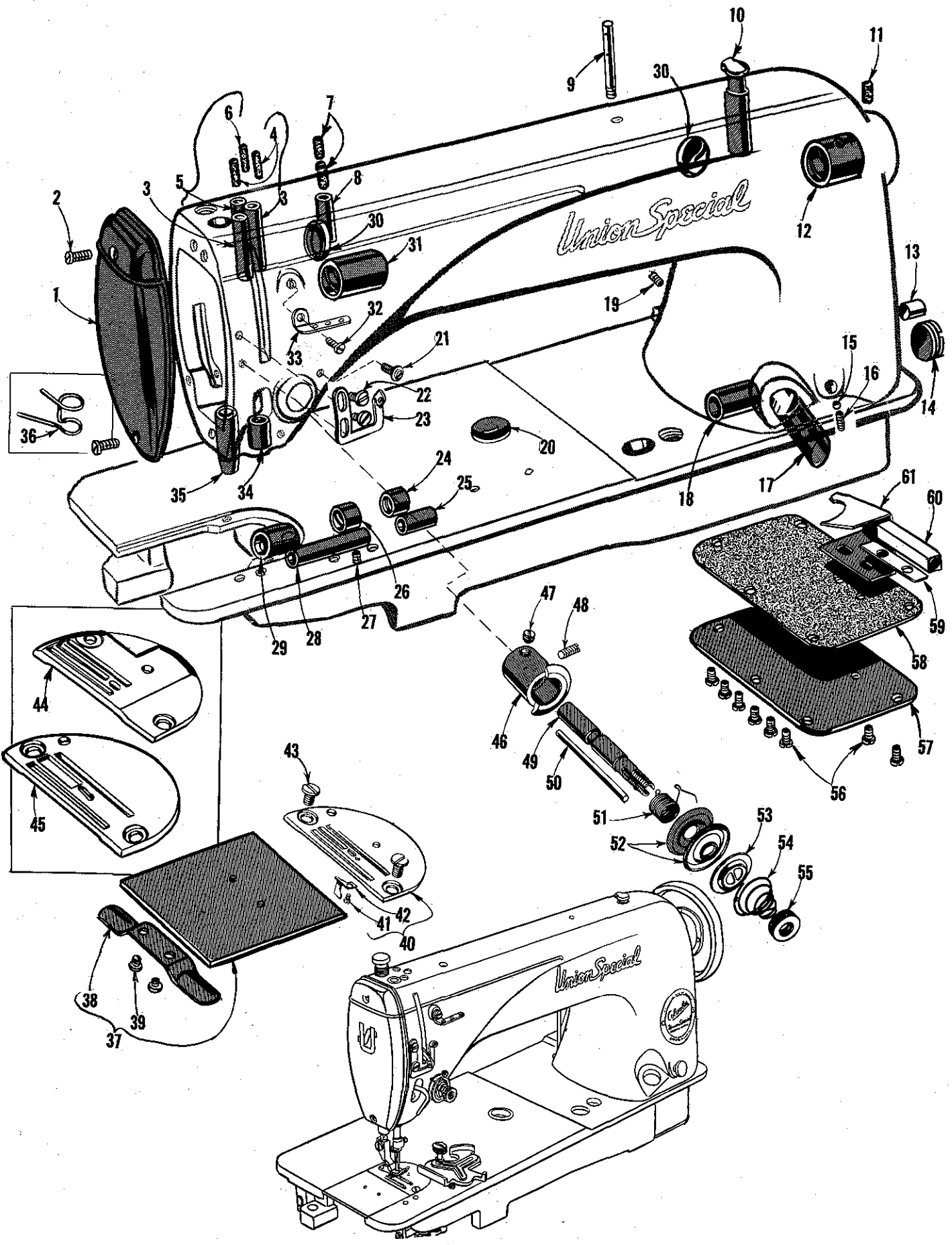

ORDERING REPAIR PARTS (Continued)

IDENTIFYING PARTS

Where the construction permits, each part is stamped with its part number. Some of the smaller parts are stamped with an identification letter to distinguish them from parts similar in appearance.

All part numbers represent the same part, regardless of the catalog in which they appear.

USE GENUINE NEEDLES AND REPAIR PARTS

Success in the operation of these machines can be secured only by the use of genuine UNION SPECIAL Needles and Repair Parts as furnished by the Union Special Corporation, its subsidiaries and authorized distributors. They are designed according to the most approved scientific principles, and are made with the utmost precision. The maximum efficiency and durability are assured.

Genuine repair parts are stamped with the Union Special trademark, U. S. Emblem. Each trademark is your guarantee of the highest quality in materials and workmanship.

TERMS

Prices are strictly net cash and subject to change without notice. All shipments are forwarded at the buyer's risk f. o. b. shipping point. Parcel Post shipments are insured unless otherwise directed. A charge is made to cover the postage and insurance.

MAIN FRAME, MISCELLANEOUS BUSHING, COVERS AND PLATES

<u>Ref. No.</u>	<u>Part No.</u>	<u>Description</u>	<u>Amt. Req.</u>
1	B61382 H	Head Cover -----	1
2	22569 B	Screw -----	2
3	61293	Oil Tube -----	2
4	666-126	Oil Wick -----	1
5	61393 C	Oil Tube -----	1
6	666-127	Oil Wick -----	1
7	666-20	Oil Wick -----	2
8	61393 B	Oil Tube -----	1
9	61272	Needle Thread Guide Pin -----	1
10	61394 AE	Oil Cup -----	1
11	666-104	Oil Wick -----	1
12	61490	Main Shaft Bushing, right -----	1
13	50-558 Blk.	Plug -----	1
14	22539 D	Plug Screw -----	1
15	61245 G	Stitch Regulator Thumb Screw Locking Insert -----	1
16	22597 A	Screw -----	1
17	50-568 Blk.	Oil Sight Gauge -----	1
18	61432 B	Feed Driving Shaft Bushing, right -----	1
19	22597 A	Screw -----	1
20	61449 H	Stitch Regulator Indicator Window -----	1
21	22863 B	Tension Assembly Adjusting Screw -----	1
22	22585 A	Screw -----	2
23	C2028	Thread Eyelet -----	1
24	61432 D	Feed Driving Shaft Oil Retaining Bushing, right -----	1
25	61341 D	Hook Shaft Bushing, right -----	1
26	61432 E	Feed Driving Shaft Oil Retaining Bushing, left -----	1
27	95	Screw -----	1
28	61341 C	Hook Shaft Bushing, left -----	1
29	61432 C	Feed Driving Shaft Bushing, left -----	1
30	61293 N	Plug, for inside of arm -----	2
31	61490 A	Main Shaft Bushing, left -----	1
32	22570 A	Screw -----	1
33	61271	Thread Eyelet -----	1
34	61454	Needle Bar Bushing, lower -----	1
35	61457 C	Presser Bar Bushing, lower -----	1
36	61470 F	Needle Bar Bushing Thread Guide, for Style 100 LS -----	1
37	61402	Bed Slide -----	1
38	61273	Bed Slide Spring -----	1
39	91 A	Screw -----	2
40	C1017 P	Throat Plate, for Style 100 P -----	1
	C1017 S	Throat Plate, for Style 100 S -----	1
41	18-983	Screw -----	1
42	C1018	Thread Retainer -----	1
43	376	Screw -----	2
44	C1017 NTN	Throat Plate, for Styles 100 TN, 100 NTN -----	1
45	C1017 LS	Throat Plate, for Style 100 LS -----	1
46	61492 A	Tension Post Socket -----	1
47	89	Set Screw -----	1
48	22597 E	Set Screw -----	1
49	61492	Tension Post -----	1
50	61292 G	Tension Release Pin -----	1
51	61453	Take-up Spring -----	1
52	109	Tension Disc -----	2
53	61292 H	Tension Release Washer -----	1
54	61392 F-9	Tension Spring -----	1
55	61292 C	Tension Nut -----	1
56	22570 A	Screw -----	8
57	61382 J	Cover, for feed driving shaft gear case -----	1
58	61282 D	Gasket -----	1
59	61394 R	Gasket -----	1
60	61394 Q	Oil Distributing Plate Retaining Block -----	1
61	61394 P	Oil Distributing Plate -----	1

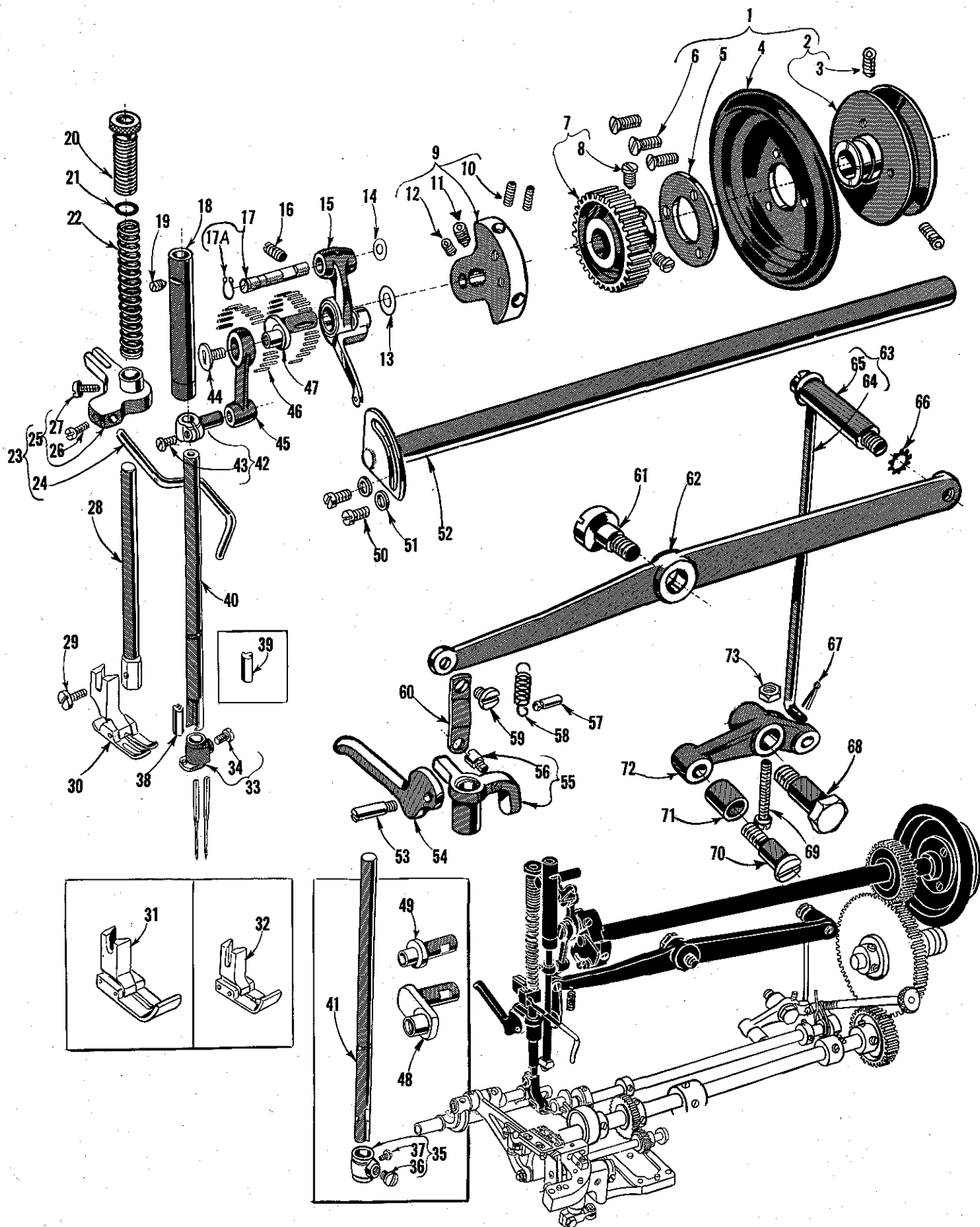

UPPER SHAFT, PRESSER BAR, NEEDLE BAR, AND FOOT LIFTER MECHANISM

<u>Ref. No.</u>	<u>Part No.</u>	<u>Description</u>	<u>Amt. Req.</u>
1	61421	Handwheel Assembly, for No. 1 "V" or Round Belt -----	1
2	61421 A	Pulley Hub -----	1
3	22894 AB	Screw -----	2
4	61321 J	Handwheel -----	1
5	61321 L	Hub Washer -----	1
6	22574	Screw -----	3
7	61360	Main Shaft Driving Gear -----	1
8	22884	Screw -----	2
9	61391 C	Main Shaft Counterweight -----	1
10	22894 V	Screw -----	2
11	22894 U	Spot Screw for Styles 100 P, 100 S -----	1
	22596 F	Set Screw for Styles 100 LS, 100 NTN -----	1
12	22894 W	Set Screw -----	1
13	61351 C	Thrust Washer -----	1
14	61451 C	Thrust Washer -----	1
15	61351 Q	Take-up Lever Assembly for Styles 100 P, 100 S, 100 NTN -----	1
	61451 H	Take-up Lever Assembly for Style 100 LS -----	1
16	22597 A	Screw -----	1
17	61251 D	Take-Up Lever Pin -----	1
17A	660-205	Retaining Ring -----	1
18	61454 D	Needle Bar Bushing, upper -----	1
19	96	Screw -----	1
20	61457 B	Presser Spring Regulator -----	1
21	61256 G	Washer -----	1
22	61256	Presser Spring -----	1
23	29475 AB	Take-up Thread Wire Assembly -----	1
24	61453 B	Take-up Spring Thread Wire -----	1
25	61459 A	Presser Bar Guide -----	1
26	77	Screw -----	1
27	93 A	Screw -----	1
28	61457	Presser Bar -----	1
29	22775	Screw -----	1
30	C1015 P	Presser Foot for Style 100 P -----	1
	C1015 S	Presser Foot for Style 100 S -----	1
31	C1015 LS	Presser Foot for Style 100 LS -----	1
32	C1015 NTN	Presser Foot for Style 100 NTN -----	1
33	C1022	Needle Clamp for Styles 100 P, 100 S, 100 NTN -----	1
34	22562	Set Screw -----	1
35	C1022 LS	Needle Clamp for Style 100 LS -----	1
36	18-623	Set Screw -----	1
37	18-621	Set Screw -----	1
38	C1021 P-062	Needle Spacer for Style 100 P -----	1
	C1021 P-073	Needle Spacer for Style 100 NTN -----	1
39	C1021 S	Needle Spacer for Style 100 S -----	1
40	C1020	Needle Bar for Styles 100 P, 100 S, 100 NTN -----	1
41	C1020 LS	Needle Bar for Style 100 LS -----	1
42	61255	Needle Bar Connection -----	1
43	22562 B	Screw -----	1
44	22757 C	Screw -----	1
45	61255 H	Needle Bar Link for Styles 100 P, 100 S, 100 NTN -----	1
	61455 C	Needle Bar Link for Style 100 LS -----	1
46	61351 K-625	Needle Bearings, .0625 inch diameter -----	38
	61351 K-626	Needle Bearings, .0626 inch diameter -----	38
	61351 K-627	Needle Bearings, .0627 inch diameter -----	38
47	61452 A	Crank Pin for Styles 100 P, 100 S -----	1
48	C1036 LS	Crank Pin for Style 100 LS -----	1
49	C1036 NTN	Crank Pin for Style 100 NTN -----	1
50	22596 D	Screw -----	2
51	8372 A	Washer -----	2
52	61322 B	Main Shaft -----	1
53	22799 M	Screw Pin -----	1
54	61265	Hand Lifter -----	1
55	61458	Presser Bar Connection -----	1
56	22892	Screw -----	1
57	61267 G	Spring Pin -----	1
58	15872 F	Spring -----	1
59	22758 B	Screw -----	1
60	61267	Lifter Lever Link -----	1
61	22890	Screw, left thread -----	1
62	61466 A	Lifter Lever -----	1
63	61368 A	Lifter Lever Extension Stud and Connecting Rod, complete -----	1
64	61368	Lifter Lever Connecting Rod -----	1
65	61366 C	Lifter Lever Extension Stud -----	1
66	652 B-20	Lock Washer -----	1
67	660-142	Cotter Pin -----	1
68	22817 A	Stud -----	1
69	22874 F	Screw -----	1
70	22712 F	Screw -----	1
71	61368 F	Roller -----	1
72	61468	Lifter Lever Bell Crank -----	1
73	9937	Nut -----	1

794

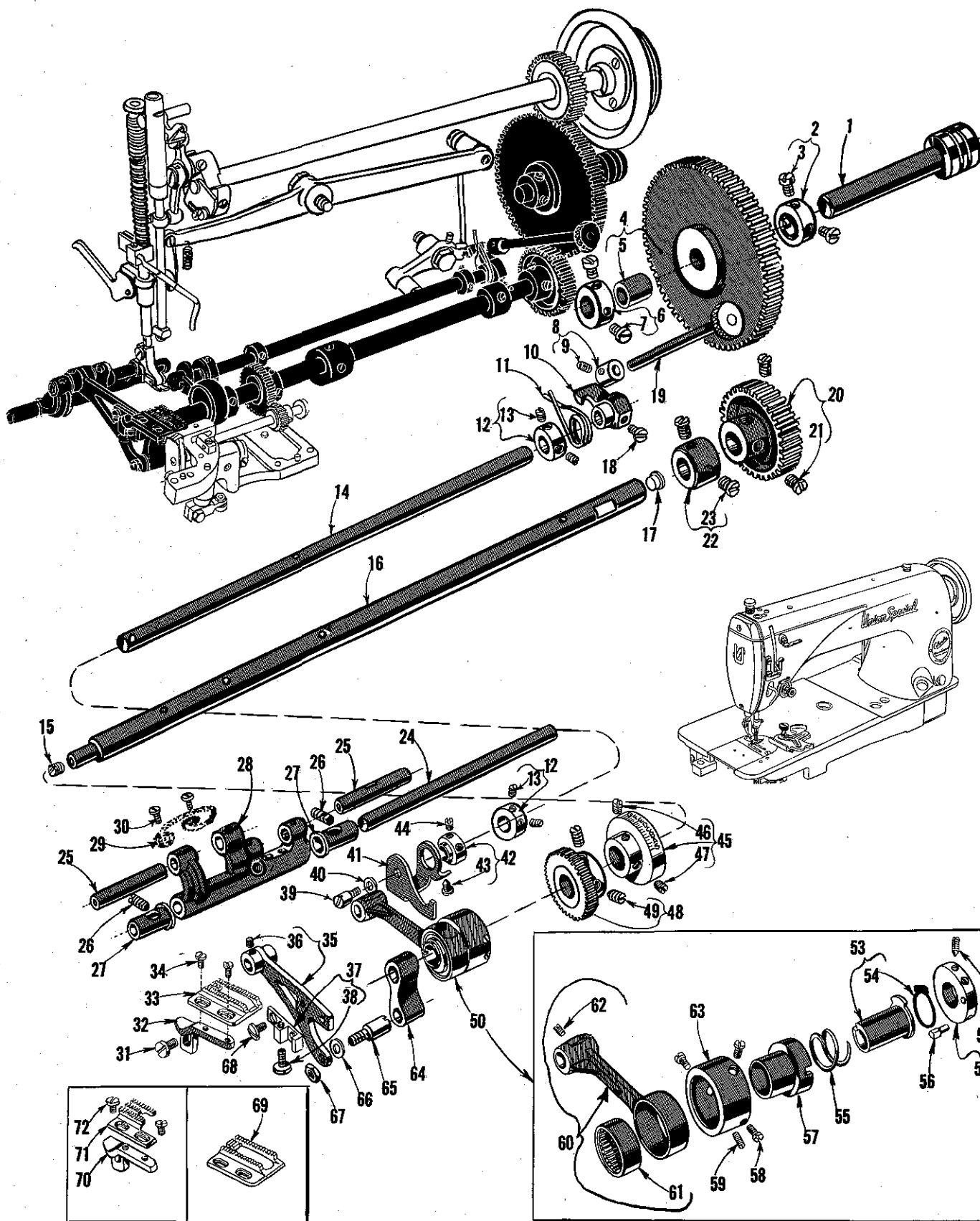

FEED DRIVING AND STITCH REGULATING MECHANISM

<u>Ref. No.</u>	<u>Part No.</u>	<u>Description</u>	<u>Amt. Req.</u>
1	62262	Intermediate Gear Shaft -----	1
2	61264	Intermediate Gear Shaft Collar, right -----	1
3	HA61 D	Screw -----	2
4	61261 A	Feed Driving Intermediate Gear -----	1
5	61263	Bushing -----	1
6	61264 A	Intermediate Gear Shaft Collar, left -----	1
7	HA61 D	Screw -----	2
8	161	Collar -----	1
9	88	Screw -----	1
10	61246 A	Stitch Regulator Plunger Lever -----	1
11	61447	Stitch Regulator Plunger Spring -----	1
12	61248 H	Stitch Regulator Shaft Collar -----	2
13	531	Screw -----	2
14	61348 A	Stitch Regulator Shaft -----	1
15	22743	Plug Screw -----	1
16	61132 D	Feed Driving Shaft, for Styles 100 P, 100 S -----	1
	61432 K	Feed Driving Shaft, for Styles 100 LS, 100 TN, 100 NTN -----	1
17	50-552 Blk.	Plug -----	1
18	93 A	Screw -----	1
19	61445	Stitch Regulator Plunger -----	1
20	61260 A	Feed Driving Shaft Gear -----	1
21	22884	Screw -----	2
22	61360 G	Feed Driving Shaft Collar -----	1
23	22884	Screw -----	2
24	61236 G	Feed Rocker Shaft -----	1
25	63435 A	Feed Bar and Feed Rocker Connection Link Shaft -----	2
26	22894 E	Screw -----	2
27	61336 U	Bushing -----	2
28	61236	Feed Rocker -----	1
29	61336 Y	Feed Rocker Oil Wick -----	1
30	90	Screw -----	2
31	22528	Screw -----	1
32	63439 A	Feed Dog Holder for Styles 100 P, 100 S, 100 LS -----	1
33	C1016 P	Feed Dog for Styles 100 P, 100 S -----	1
34	22768	Screw -----	2
35	63434 C	Feed Bar -----	1
36	89	Screw -----	1
37	63439 AL	Feed Dog Holder Support -----	1
38	22775 A	Screw -----	1
39	22802 A	Screw -----	1
40	51242 M	Washer -----	1
41	61449 F	Stitch Regulating Pawl -----	1
42	61449 E	Stitch Regulating Pawl Collar -----	1
43	22880	Screw -----	1
44	22845 G	Screw -----	1
45	61149	Stitch Length Indicator -----	1
46	95	Set Screw -----	1
47	96	Time Spot Screw -----	1
48	61443	Hook Shaft Driving Gear -----	1
49	22894 J	Set Screw -----	2
50	29126 DU	Feed Drive Eccentric Assembly, for Styles 100 P, 100 S, marked "DU" -----	1
	29126 DT	Feed Drive Eccentric Assembly, for Style 100 LS, marked "DT" -----	1
	29126 DS	Feed Drive Eccentric Assembly, for Styles 100 TN, 100 NTN, marked "DS" -----	1
51	61437 A	Feed Driving Eccentric Timing Collar -----	1
52	22764 B	Time Spot Screw, for Styles 100 P, 100 S -----	1
	719	Time Set Screw, for Styles 100 LS, 100 TN, 100 NTN -----	1
53	61149 G	Stitch Regulating Eccentric, for Styles 100 P, 100 S -----	1
	61449 AB	Stitch Regulating Eccentric, for Styles 100 LS, 100 TN, 100 NTN -----	1
54	61149 H	Stitch Regulating Eccentric Friction Disc -----	1
55	61449 B	Stitch Regulating Thrust Spring -----	1
56	61437 B	Feed Driving Eccentric Pivot Pin, for Styles 100 P, 100 S -----	1
	61437 U	Feed Driving Eccentric Pivot Pin, for Styles 100 LS, 100 TN, 100 NTN -----	1
57	61137	Feed Driving Eccentric, on Styles 100 P, 100 S -----	1
58	22564 B	Screw -----	3
59	719	Screw -----	1 or 2
60	61438 C	Connecting Rod -----	1
61	660-226	Needle Bearing -----	1
62	88	Screw -----	1
63	61437 C	Feed Driving Eccentric Retaining Housing -----	1
64	61233 N	Feed Link -----	1
65	22845 D	Feed Link Stud -----	1
66	61434 G	Washer -----	1
67	15037 A	Nut -----	1
68	88 D	Screw -----	1
69	C1016 LS	Feed Dog, for Style 100 LS -----	1
70	61439 AW	Feed Dog Holder, for Styles 100 TN, 100 NTN -----	1
71	C1016 NTN	Feed Dog, for Styles 100 TN, 100 NTN -----	1
72	22768	Screw -----	2

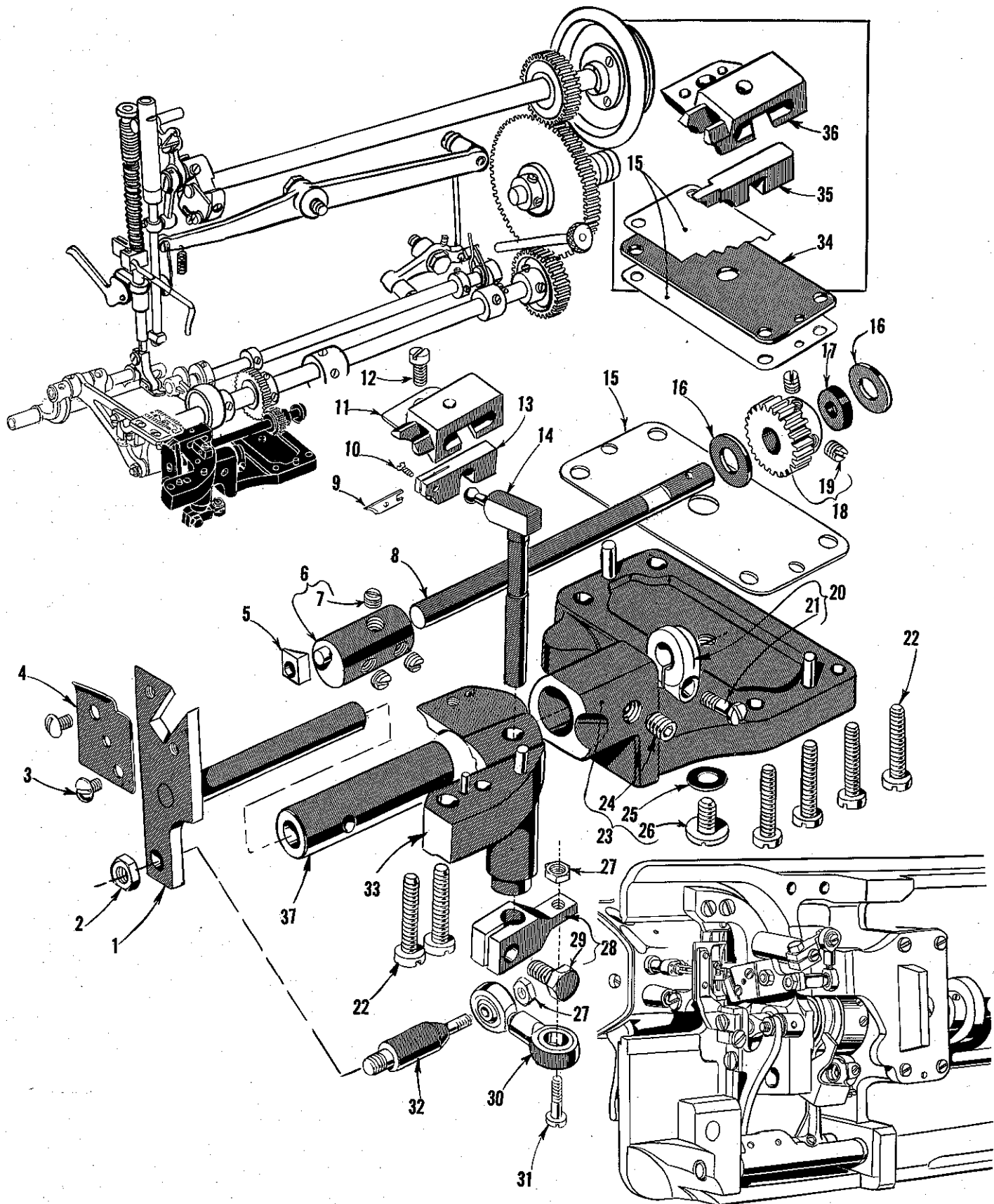

HOOK, PLUNGER, AND DRIVING MECHANISM

<u>Ref. No.</u>	<u>Part No.</u>	<u>Description</u>	<u>Amt. Req.</u>
1	C1033 P	Hook Carrier for Styles 100 P, 100 NTN-----	1
	C1033 S	Hook Carrier for Style 100 S, 100 LS-----	1
2	1160 L	Nut-----	1
3	C717	Screw-----	2
4	C1008 P	Looper Hook-----	1
5	C1032	Slide Block-----	1
6	C1030	Hook Shaft Barrel for Styles 100 P, 100 S, 100 NTN-----	1
	C1030 LS	Hook Shaft Barrel for Style 100 LS-----	1
7	18-634	Set Screw-----	3
8	61440 A	Hook Shaft-----	1
9	C1023	Plunger for Styles 100 P, 100 S, 100 NTN-----	1
10	18-134	Screw for Styles 100 P, 100 S, 100 NTN-----	1
11	C1019	Plunger Block for Styles 100 P, 100 S, 100 NTN----	1
12	22562 A	Screw-----	1
13	C1024 P	Plunger Slide for Styles 100 P, 100 NTN-----	1
	C1024 S	Plunger Slide for Style 100 S-----	1
14	C1025	Plunger Ball Crank-----	1
15	61482 R-3	Shim Gasket, .003 inch thick (as required)-----	
	61482 R-10	Shim Gasket, .010 inch thick (as required)-----	
16	61341 J	Thrust Washer-----	2
17	61341 G	Oil Seal Washer-----	1
18	61244	Hook Shaft Pinion-----	1
19	89	Set Screw-----	2
20	439-C116 R	Collar-----	1
21	22562 A	Screw-----	1
22	22874	Screw-----	6
23	C1002 P	Hook Bracket-----	1
24	22650 AD-4	Set Screw-----	1
25	660-257	Gasket-----	1
26	18-C87	Screw-----	1
27	1311 L	Nut-----	2
28	C1029 LS	Plunger Crank-----	1
29	18-715	Clamp Screw-----	1
30	C1034	Ball Joint-----	1
31	916 L	Screw-----	1
32	C1035	Connection Stud-----	1
33	C1027	Plunger Bracket-----	1
34	C1069	Gasket for Style 100 LS-----	1
35	C1024 LS	Plunger Slide for Style 100 LS-----	1
36	C1019 LS	Plunger Block for Style 100 LS-----	1
37	C1000-1	Hook Carrier Shaft Bushing-----	1

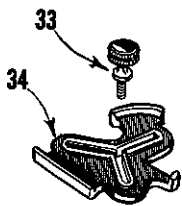
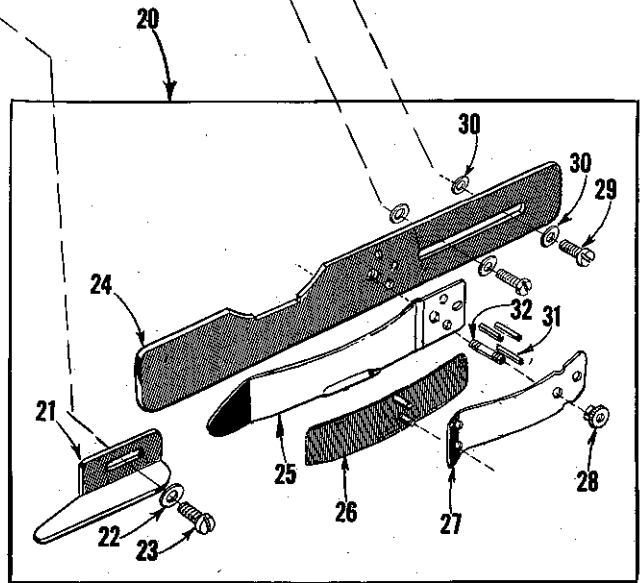
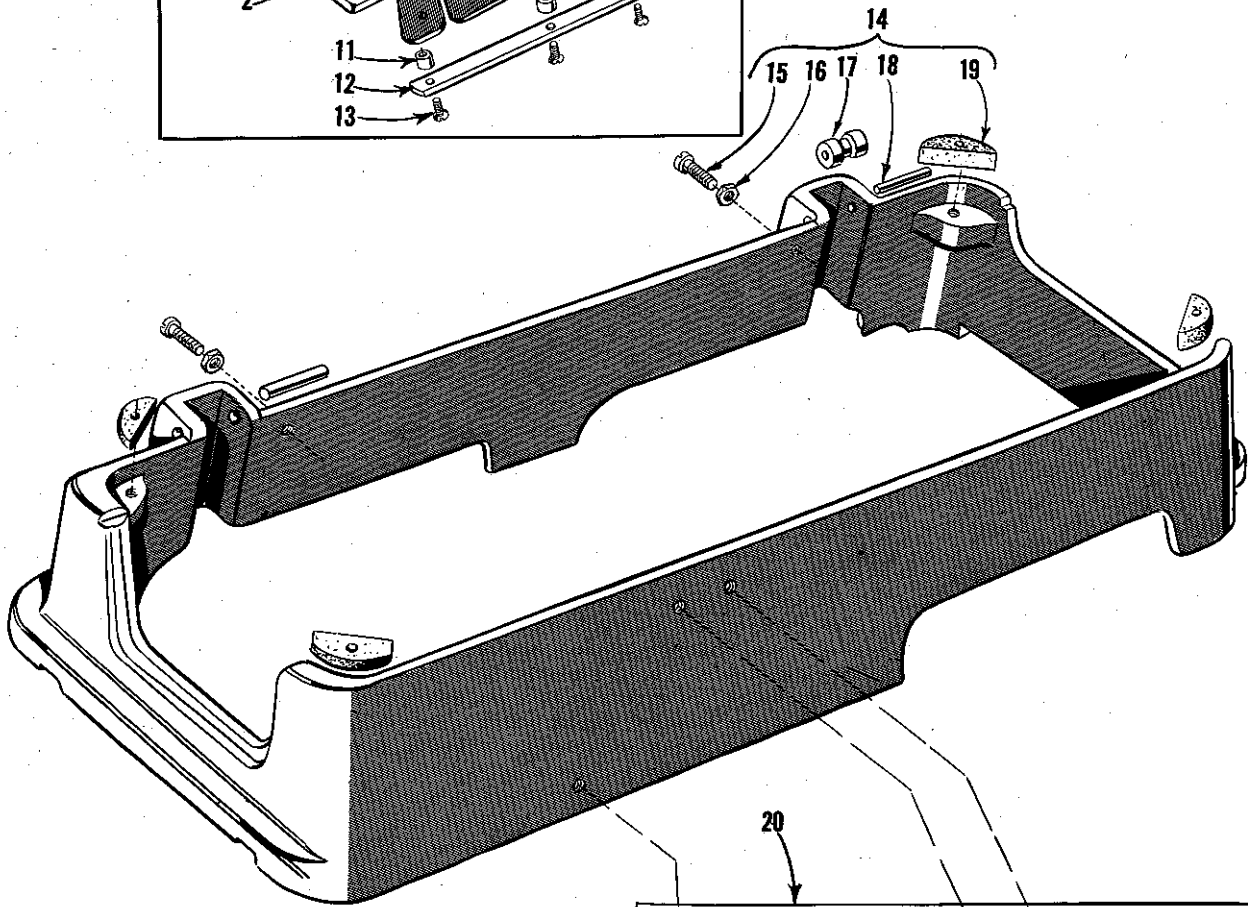
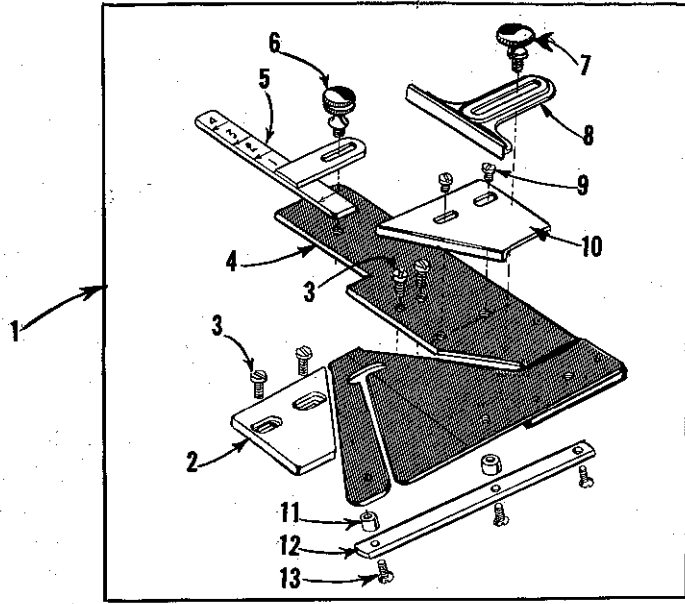

ATTACHMENTS

<u>Ref. No.</u>	<u>Part No.</u>	<u>Description</u>	<u>Amt. Req.</u>
1	C1078 A	Tie Centralizer Plate, complete, for Styles 100 TN, 100 NTN -----	1
2	C1073	Adjusting Plate, left -----	1
3	22585	Mounting Screw -----	4
4	C1077 A	Centralizer and Plate Assembly -----	1
5	C1049 A	Reference Plate and Bracket Assembly -----	1
6	22551 B	Knurled Thumbscrew -----	1
7	15489 B	Knurled Thumbscrew -----	1
8	C1059	Edge Guide -----	1
9	22513	Screw -----	2
10	C1074	Adjusting Plate, right -----	1
11	C1054	Washer -----	2
12	C1053	Tape Bar -----	1
13	87 A	Screw -----	3
14	C1039 A	Machine Base, complete, for Styles 100 TN, 100 NTN -----	1
15	650 AD-6	Screw -----	2
16	651 H	Nut -----	2
17	C1042	Hinge Pin Collar -----	1
18	39132 G	Hinge Pin -----	2
19	61476	Felt Pad -----	4
20	C1076 A	Lining Stretcher Gauge, complete, for Styles 100 TN, 100 NTN -----	1
21	C1066	Lining Guide -----	1
22	40-38	Washer -----	1
23	650 AD-5	Screw -----	1
24	C1061	Back Plate -----	1
25	C1075	Bottom Lining Pad -----	1
26	C1072	Spring -----	1
27	C1071	Spring -----	1
28	20-C616	Nut -----	1
29	650 AD-5	Screw -----	2
30	40-38	Washer -----	4
31	22-C214-2	Pin -----	3
32	68-C614	Screw -----	1
33	G26	Screw, for Styles 100 P, 100 S, 100 LS -----	1
34	61403 B	Edge Guide, for Styles 100 P, 100 S, 100 LS -----	1

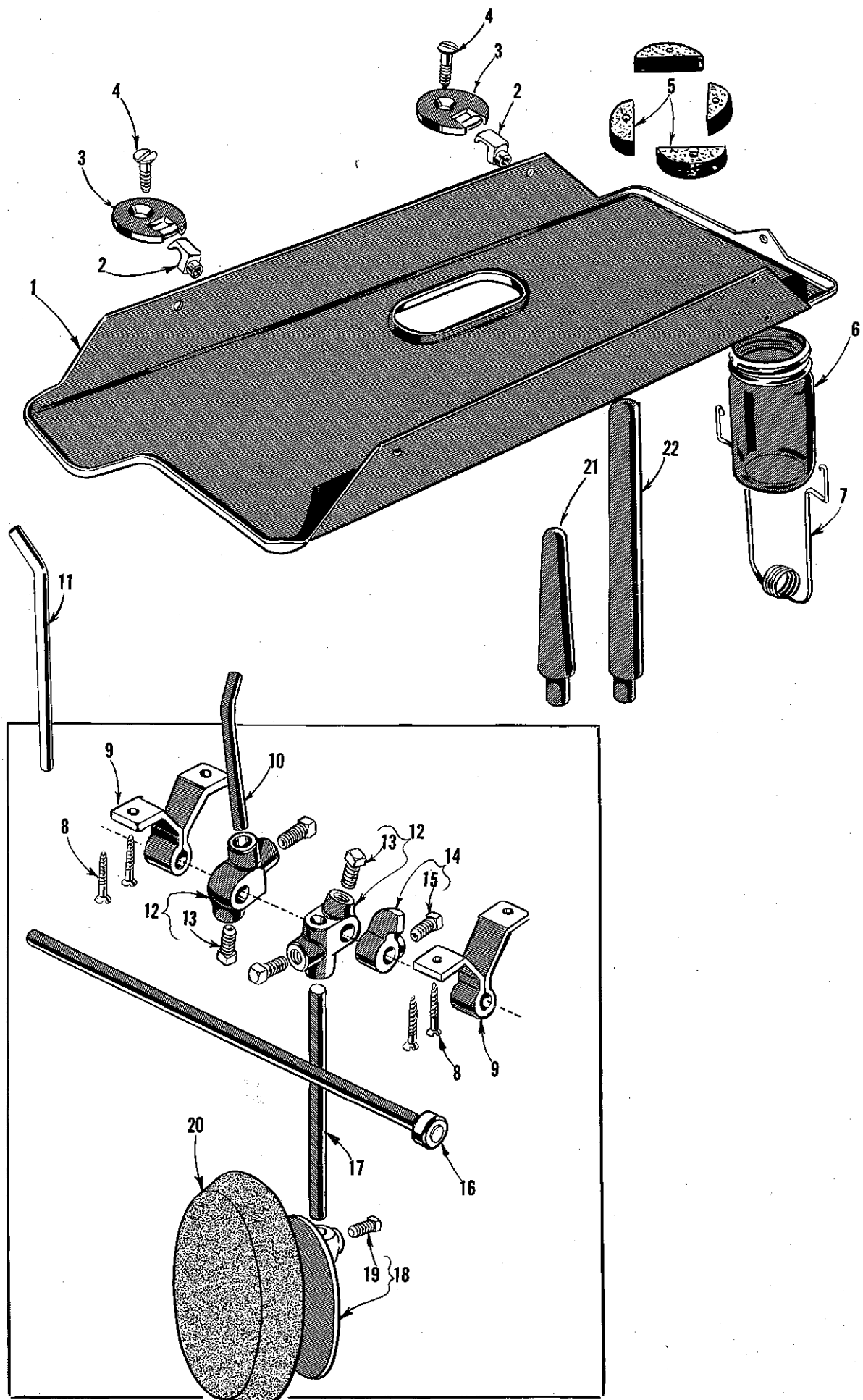

INSTALLATION ACCESSORIES

Ref. No.	Part No.	Description	Amt. Req.
1	21393 E	Drip Pan -----	1
2	61175	Hinge Stud-----	2
3	61374	Hinge Plate for Styles 100 P, 100 S, 100 LS-----	2
4	22846 Q-16	Flat Head Wood Screws for Styles 100 P, 100 S, 100 LS-----	2
5	61376 G	Felt Pad for Styles 100 P, 100 S, 100 LS -----	4
6	666-166	Oil Drain Jar, glass-----	1
7	21393 F	Oil Drain Jar Clamp Spring -----	1
8	SC329 A	Wood Screws, for knee lifter hanger -----	4
9	21662 C	Knee Lifter Hanger-----	2
10	21665 C	Knee Lifter Rock Shaft Connection Arm for Styles 100 P, 100 S, 100 LS-----	1
11	C1038	Knee Lifter Rock Shaft Connection Arm for Style 100 NTN-----	1
12	21665	Knee Lifter Rock Shaft Connection -----	2
13	69 FD	Screw -----	2
14	21661 D	Knee Lifter Rock Shaft Stop -----	1
15	69 FD	Screw -----	1
16	21661 P	Knee Lifter Rock Shaft-----	1
17	21663 C	Knee Lifter Plate Rod -----	1
18	21664	Knee Lifter Plate -----	1
19	69 FD	Screw -----	1
20	660-168	Knee Pad, rubber -----	1
21	61378	Machine Rest Pin for Styles 100 P, 100 S, 100 LS ----	1
22	61378 A	Machine Rest Pin for Style 100 NTN-----	1

NUMERICAL INDEX OF PARTS

Part No.	Page No.	Part No.	Page No.	Part No.	Page No.	Part No.	Page No.
18-C87.....	25	C1024 P.....	25	22775	21	61351 K-627.....	21
18-134.....	25	C1024 S.....	25	22775 A.....	23	61351 Q.....	21
18-621.....	21	C1024 LS.....	25	22799 M.....	21	61360.....	21
18-623.....	21	C1025	25	22802 A.....	23	61360 G.....	23
18-634.....	25	C1027	25	22817 A.....	21	61366 C.....	21
18-715.....	25	C1029 LS.....	25	22845 D.....	23	61368.....	21
18-983.....	19	C1030	25	22845 G.....	23	61368 A.....	21
20-C616.....	27	C1030 LS.....	25	22846 Q-16.....	29	61368 F.....	21
22-C214-2.....	27	C1032	25	22863 B.....	19	61374.....	29
G26.....	27	C1033 P.....	25	22874	25	61376 G.....	29
40-38.....	27	C1033 S.....	25	22874 F.....	21	61378.....	29
50-552 Blk.....	23	C1034	25	22880	23	61378 A.....	29
50-558 Blk.....	19	C1035	25	22884	21, 23	B61382 H.....	19
50-568 Blk.....	19	C1036 LS.....	21	22890	21	61382 J.....	19
HA61 D.....	23	C1036 NTN.....	21	22892	21	61391 C.....	21
68-C614.....	27	C1038	29	22894 E.....	23	61392 F-9.....	19
69 FD.....	29	C1039 A.....	27	22894 J.....	23	61393 B.....	19
77.....	21	C1042	27	22894 V.....	21	61393 C.....	19
87 A.....	27	C1049 A.....	27	22894 U.....	21	61394 P.....	19
88.....	23	C1053	27	22894 W.....	21	61394 Q.....	19
88 D.....	23	C1054	27	22894 AB.....	21	61394 R.....	19
89.....	19, 23, 25	C1059	27	29126 DS.....	23	61394 AE.....	19
90.....	23	C1061	27	29126 DT.....	23	61402.....	19
91 A.....	19	C1066	27	29126 DU.....	23	61403 B.....	27
93 A.....	23	C1069	25	29475 AB.....	21	61421.....	21
95.....	19, 23	C1071	27	39132 G.....	27	61421 A.....	21
96.....	21, 23	C1072	27	51242 M.....	23	61432 B.....	19
109.....	19	C1073	27	61132 D.....	23	61432 C.....	19
161.....	23	C1074	27	61137	23	61432 D.....	19
SC329 A.....	29	C1075	27	61149	23	61432 E.....	19
376.....	19	C1076 A.....	27	61149 G.....	23	61432 K.....	23
439-C116 R.....	25	C1077 A.....	27	61149 H.....	23	61434 G.....	23
531.....	23	C1078 A.....	27	61175	29	61437 A.....	23
650 AD-5.....	27	1160 L.....	25	61233 N.....	23	61437 B.....	23
650 AD-6.....	27	1311 L.....	25	61236	23	61437 C.....	23
651 H.....	27	C2028	19	61236 G.....	23	61437 U.....	23
652 B-20.....	21	8372 A.....	21	61244	25	61438 C.....	23
660-142.....	21	9937.....	21	61245 G.....	19	61439 AW.....	23
660-168.....	29	15037 A.....	23	61246 A.....	23	61440 A.....	25
660-205.....	21	15489 B.....	27	61248 H.....	23	61443.....	23
660-226.....	23	15872 F.....	21	61251 D.....	21	61445.....	23
660-257.....	25	21393 E.....	29	61255	21	61447.....	23
666-20.....	19	21393 F.....	29	61255 H.....	21	61449 B.....	23
666-104.....	19	21661 D.....	29	61256	21	61449 E.....	23
666-126.....	19	21661 P.....	29	61256 G.....	21	61449 F.....	23
666-127.....	19	21662 C.....	29	61260 A.....	23	61449 H.....	19
666-166.....	29	21663 C.....	29	61261 A.....	23	61449 AB.....	23
C717.....	25	21664.....	29	61263	23	61451 C.....	21
719.....	23	21665.....	29	61264	23	61451 H.....	21
916 L.....	25	21665 C.....	29	61264 A.....	23	61452 A.....	21
C1000-1.....	25	22513.....	27	61265.....	21	61453.....	19
C1002 P.....	25	22528.....	23	61267.....	21	61453 B.....	21
C1008 P.....	25	22539 D.....	19	61267 G.....	21	61454.....	19
C1015 P.....	21	22551 B.....	27	61271	19	61454 D.....	21
C1015 S.....	21	22562	21	61272	19	61455 C.....	21
C1015 LS.....	21	22562 A.....	25	61273	19	61457.....	21
C1015 NTN.....	21	22562 B.....	21	61282 D.....	19	61457 B.....	21
C1016 P.....	23	22564 B.....	23	61292 C.....	19	61457 C.....	19
C1016 LS.....	23	22569 B.....	19	61292 G.....	19	61458.....	21
C1016 NTN.....	23	22570 A.....	19	61292 H.....	19	61459 A.....	21
C1017 P.....	19	22574	21	61293	19	61466 A.....	21
C1017 S.....	19	22585	27	61293 N.....	19	61468.....	21
C1017 LS.....	19	22585 A.....	19	61321 J.....	21	61470 F.....	19
C1017 NTN.....	19	22596 D.....	21	61321 L.....	21	61476.....	27
C1018.....	19	22596 F.....	21	61322 B.....	21	61482 R-3.....	25
C1019.....	25	22597 A.....	19, 21	61336 U.....	23	61482 R-10.....	25
C1019 LS.....	25	22597 E.....	19	61336 Y.....	23	61490.....	19
C1020.....	21			61341 C.....	19	61490 A.....	19
C1020 LS.....	21	22650 AD-4.....	25	61341 D.....	19	61492.....	19
C1021 P-062.....	21	22712 F.....	21	61341 G.....	25	61492 A.....	19
C1021 P-073.....	21	22743.....	23	61341 J.....	25	62262.....	23
C1021 S.....	21	22757 C.....	21	61348 A.....	23	63434 C.....	23
C1022.....	21	22758 B.....	21	61351 C.....	21	63435 A.....	23
C1022 LS.....	21	22764 B.....	23	61351 K-625.....	21	63439 A.....	23
C1023.....	25	22768.....	23	61351 K-626.....	21	63439 AL.....	23

Union Special Wants to Help You Cut Sewing Machine Maintenance Costs

Union Special is offering two practical systems to help pinpoint and reduce your sewing machine maintenance costs: a record keeping system to help spot machines requiring abnormally high maintenance, and a parts inventory system to speed routine repairs.

Machine Maintenance Records

Repair-prone machines or inexperienced competent operators can eat up your maintenance dollars in short order. To help spot these problems, Union Special suggests two variations of a simple maintenance record keeping system using cards provided by Union Special.

The first system utilizes a "Machine Maintenance Record" card (Form 237) for each sewing machine in a plant. When a repair is required, the card is pulled from the file and the repair date, parts used, and their cost are entered in the spaces provided and the card is refiled.

The second system is normally used when more detailed information on repair costs is desired. Two record cards are used: a "Repair Request Card" (Form 234), and a "Machine Repair Record" (Form 233). When a machine requires service, the forelady or foreman fills out the top of a "Repair Request Card" and gives it to a mechanic. He fills in the time the repair work is started, the parts used and their cost,

and the completion time. This data is then transferred to the permanent "Machine Repair Record" kept in the office.

Whichever system is used, management now has an invaluable tool to reduce needless maintenance costs.

Repair Part Inventories

While record keeping tells management which machines require abnormally high maintenance, it does little to help reduce the downtime caused by routine repairs. To alleviate this situation, Union Special recommends that manufacturers establish a formal parts inventory system for each type of sewing machine they operate.

Excessive machine downtime and wasted hours by mechanics can be eliminated with an orderly in-plant inventory of the most commonly needed parts. There is no longer a need to cannibalize other machines for spare parts. Long waits for deliveries are avoided and machine downtime is kept to a minimum. The cost of a parts inventory is small when the overall savings are considered.

For free sample copies of the machine record cards and spare part inventory lists for a variety of the most popular machines, contact your local Union Special Representative or write direct to Union Special.

U *Union Special*
Industrial Sewing Equipment

Style 100 P

Suggested Minimum Spare Parts List*

Part Number	Description	Minimum Quantity Per 5 Machines	Part Number	Description	Minimum Quantity Per 5 Machines
C1015 P	Presser Foot	1	C1008 P	Looper Hook	1
22775	Screw for Presser Foot	1	C717	Screw for Looper Hook	2
C1016 P	Feed Dog	1	61453	Take-up Spring	3
22768	Screw for Feed Dog	2	61470 F	Needle Bar Bushing Thread Guide	2
C1017 P	Throat Plate	1	C1023	Plunger	1
376	Screw for Throat Plate	2	18-134	Screw for Plunger	2
29-C150	Needles (specify size) Eye Needle	200	C1018	Thread Retainer	1
29-C151	Needles (specify size) Hook Needle	200	18-45	Screw for Retainer	1
C1021 P-062	Needle Spacer	2	29484	Screw Assortment	1
22562	Needle Set Screw	2			

*The parts and quantities listed above are intended to assist you in setting up the initial inventory of spare parts. An efficient inventory can only be established according to actual usage. The nature of the sewing operation will determine actual usage.

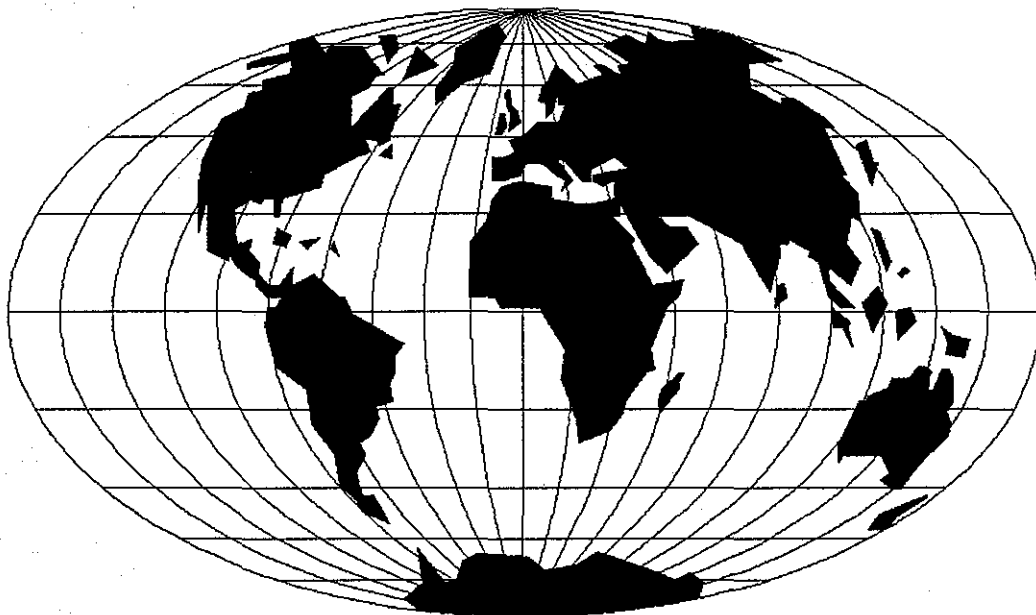

WORLDWIDE SALES AND SERVICE

Union Special Corporation maintains sales and service facilities throughout the world. These offices will aid you in the selection of the right sewing equipment for your particular operation. Union Special Corporation representatives and service technicians are factory trained and are able to serve your needs promptly and efficiently. Whatever your location, there is a qualified representative to serve you.

Corporate Office: One Union Special Plaza
Huntley, IL 60142
Phone: 847•669•5101
Fax: 847•669•4454

European Distribution Center: Union Special GmbH
Raiffelsenstrasse 3
D-71696 Möglingen, Germany
Tel: 49•07141•247•0
Fax: 49•7141•247•100

Brussels, Belgium
Charlotte, N.C.
El Paso, TX
Hong Kong, China
Huntley, IL
Leicester, England
Lille, France
Miami, FL
Milan, Italy
Möglingen, Germany
Montreal, Quebec
Osaka, Japan
Santa Fe Springs, CA

Other Representatives throughout
all parts of the world.



Union Special
INDUSTRIAL SEWING EQUIPMENT